

# Designed for swing out glass doors on a wood frame.

Enhance customer service. Increase sales.



The Showcase Lock is beautifully designed and will enhance the appearance of glass door display cases and can easily be installed on single or double doors. In some applications one Showcase Lock can often two mechanical locks. Operational efficiency, improved customer service and speed to checkout makes Smart Lock

the perfect locked cabinet solution.

- › Sales associates have access to locked display cabinets, delivering a more timely response to customers
- › Enhanced interaction with customers results in increased sales



## Showcase Lock

### FEATURES AND BENEFITS

- 1 Designed for swing-out glass doors
- 2 Brace option enables protection of double doors with a single lock
- 3 Simple installation with common tools
- 4 No re-keying of locks when keys are lost, broken or stolen
- 5 Lock Status Indicator provides visual confirmation that lock is locked or unlocked
- 6 Showcase Lock is part of the exclusive InVue single key IR Ecosystem™

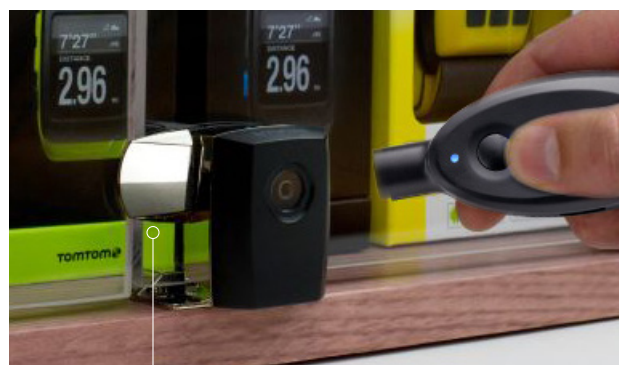
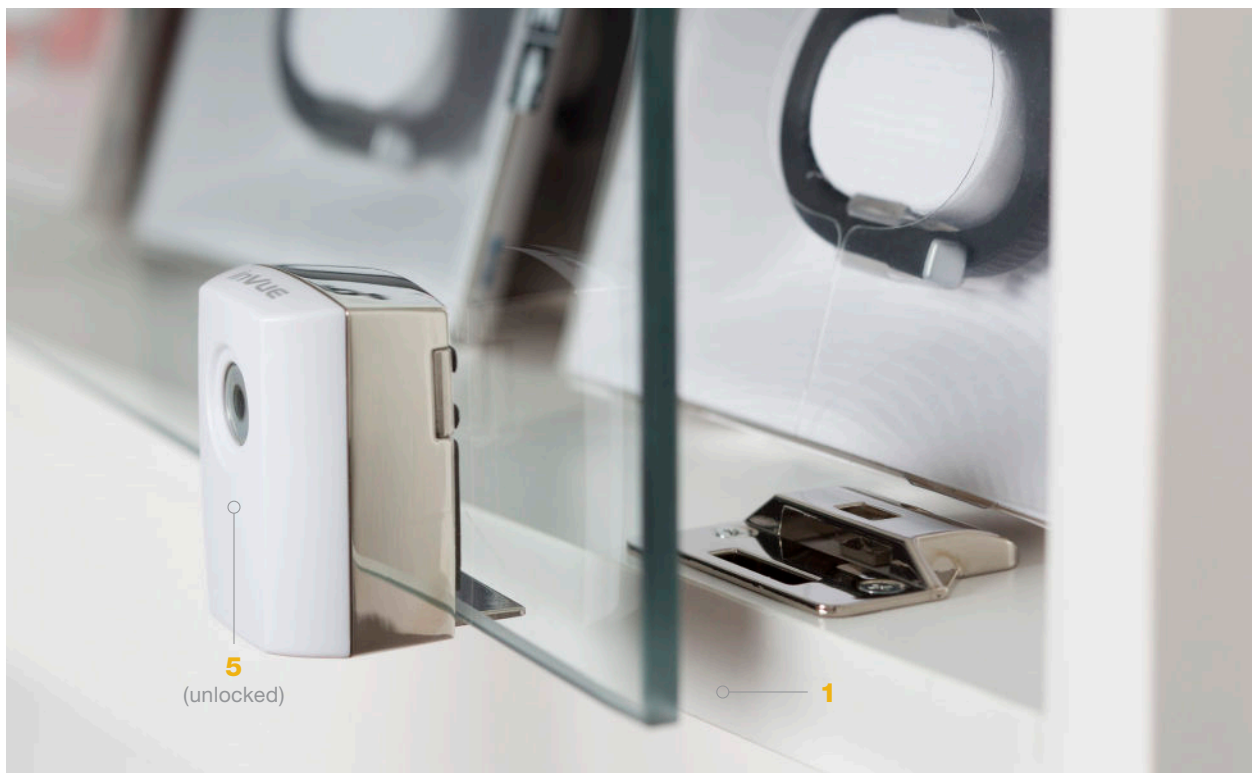

## Showcase Lock



### IR ECOSYSTEM™

The Showcase Lock is part of the exclusive InVue IR Ecosystem™, a storewide single key solution that improves customer service, increases sales and provides high theft protection.

InVue has a full line of Smart Locks that are designed for all types of glass, wood and metal locked cabinets including:

- › Pull out drawers
- › Swing out doors
- › Sliding bypass doors



Handheld Electronics

Electronic Accessories

Locked Cabinets

Commercial Solutions



# Showcase Lock

## SPECIFICATIONS

Showcase Lock (PL401):

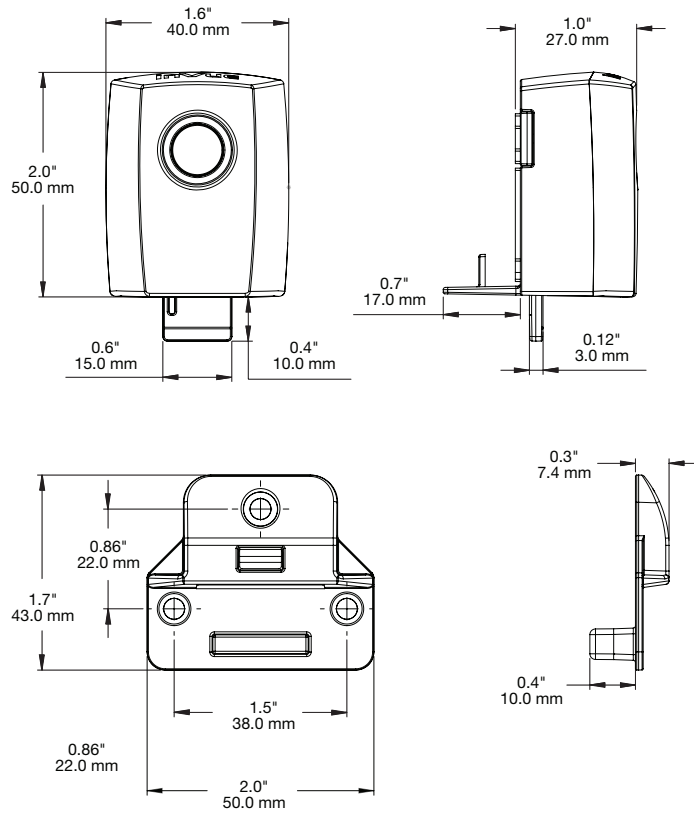

Brace Accessory (PL420-01):

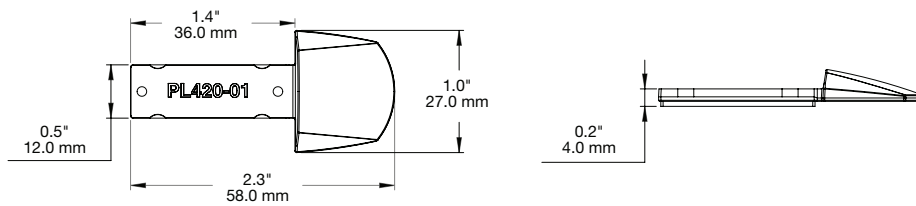

## Showcase Lock

---

### PRODUCT ORDERING

| ORDER CODE         | DESCRIPTION                                    | NOTES | CARTON QTY. |
|--------------------|--|-------|-------------|
| PL401-B<br>PL401-W | Showcase Lock – Black<br>Showcase Lock – White |       | 25          |
| PL140-01           | Brace Accessory Kit                            |       | 25          |
| PL441              | Replacement Adhesives (for PL401)              |       | 25          |
| PL451              | Removal Tool                                   |       | 25          |

[invue.com](http://invue.com)

©2016 InVue Security Products. No endorsement of InVue products has been made by any of the manufacturers of the products shown. Product is sold pursuant to InVue's warranty which can be found at [www.invue.com/warranty](http://www.invue.com/warranty).

**THE AMERICAS** 704.752.6513 • 888.55.INVUE  
**EUROPE, MIDDLE EAST & AFRICA** +31.23.8900150  
**ASIA PACIFIC** +852.3127.6811

**invue**

rev. 12/19/16

