

Packaged merchandise, visible and secure.



- › IR Package Wrap allows for easy customer interaction with merchandise
- › Alarm unit on top of package allows better visibility of package graphics and information
- › Allows open display of merchandise while providing robust security
- › Designed for shelved merchandise and peg hooks
- › 90 dB alarm
- › EAS tower alarms (AM and RF)
- › Part of InVue's IR Ecosystem™



FEATURES AND BENEFITS

- 1 Alarm unit on top of package enables better shelf stacking and does not obstruct package graphics and information
- 2 Cable connectors allow efficient cable management
- 3 Reinforced integrated hang tag cannot be removed making it highly secure when combined with InVue Secure Fixtures
- 4 IR2 Key compatibility for fast access to merchandise to better serve the consumer
- 5 IR2 Key times out after 12 hours, making a lost or stolen key useless
- 6 LED blinks red, indicating active status
- 7 Easy grip design enables efficient cable retraction
- 8 90dB alarm if cable is cut
- 9 Cable can be wound with key fob

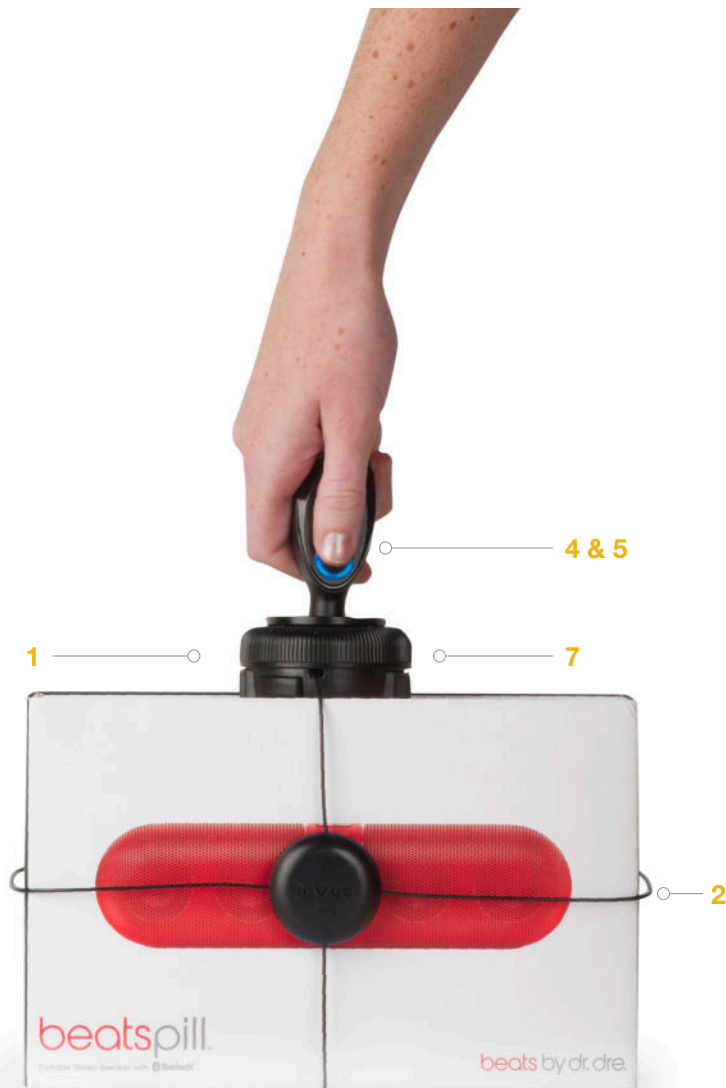

APPLICATIONS



Reinforced integrated hang tab compliments NL11



NW102



NW70





IR ECOSYSTEM™

A storewide single key security system for all your high theft merchandise. One key and four categories of tough security products provide you multiple, store-wide security solutions. The IR Ecosystem™ allows you to safely open display, and access, your high theft merchandise and ensures that store associates always have the right key at the right time.

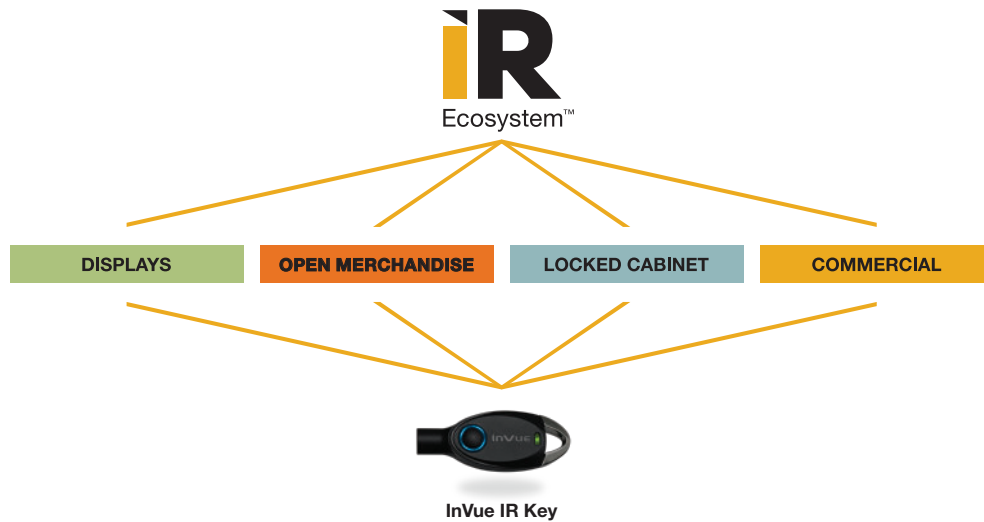

SPECIFICATIONS

IR Package Wrap 70" (NW70):

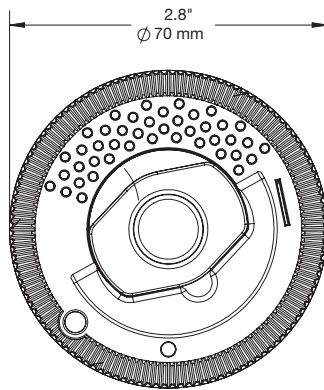

Alarm Unit

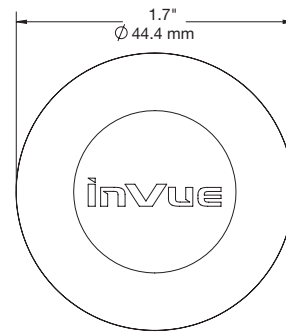
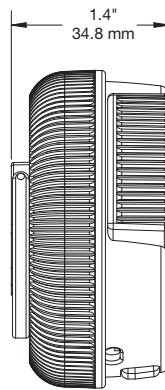

Cable Medallion

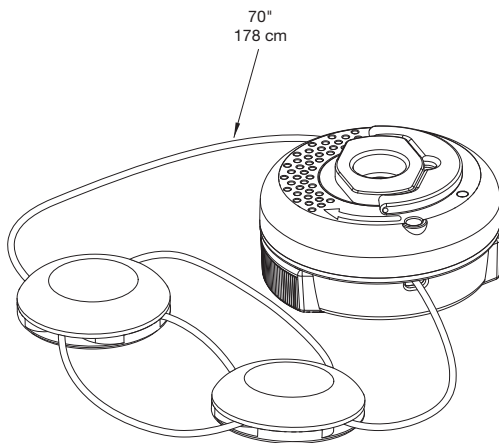
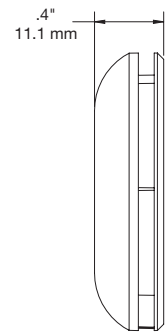

Alarm unit, cable medallion & cable



SPECIFICATIONS

IR Package Wrap 102" (NW102):

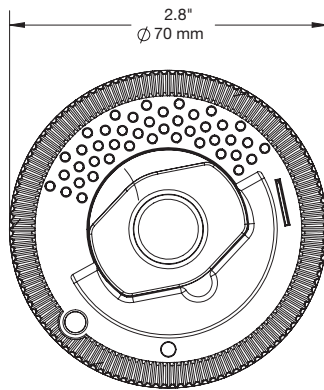

Alarm Unit

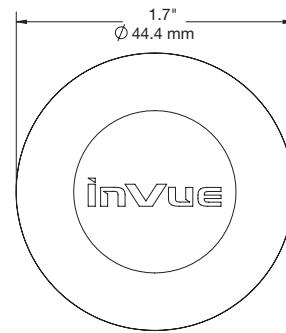
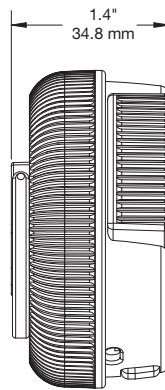

Cable Medallion

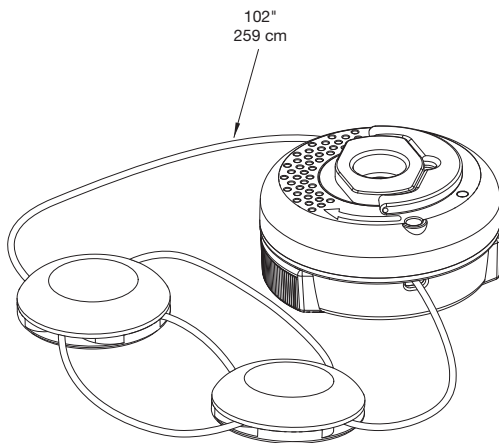
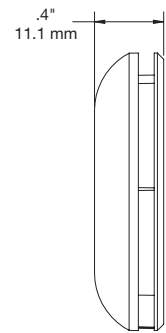

Alarm unit, cable medallion & cable



PRODUCT ORDERING

ORDER CODE	DESCRIPTION	CARTON QTY.
NW70	IR Package Wrap 70"	12
NW102	IR Package Wrap 102"	12

©2015 InVue Security Products. No endorsement of InVue products has been made by any of the manufacturers of the products shown. Product is sold pursuant to InVue's warranty which can be found at www.invue.com/warranty.

NA / LATAM OFFICE *North Carolina* 704.752.6513 • 888.55.INVUE

EMEA OFFICE *The Netherlands* +31.23.8900150

APAC OFFICE *Hong Kong* +852.3127.6811

